



# PRODUCT SUPPORT.....SERVICE NEWS

<b>BULLETIN NO.: 2004-001</b>	<b>DATE: Oct. 8, 2004</b>	<b>PAGE: 1 of 3</b>
<b>TITLE: Seat Slide Adjustment</b>	<b>RELEASE: Dealer/Customer</b>	
<b>SECTION: Cab [All with Sears Mfg. Seat]</b>	<b>MODEL: 50~115ZIV-2/ZV</b>	

## GENERAL:

The purpose of this document is to explain how to adjust seat slides on Sears Manufacturing seats.

## DETAIL:

Prior to continuing, determine if the seat slides need to be adjusted by checking the following items.

1. Check the side to side movement of the seat assembly. There should be only a small amount of motion when the seat is "loaded" from one side to the other.

Check Movement

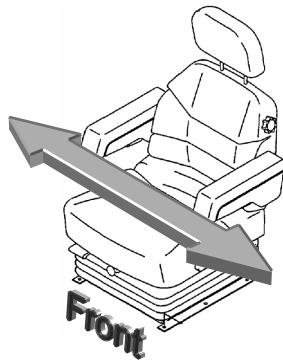

2. If there is excess movement, determine where the movement is greatest. Suspension parts may be worn, or the slide may have developed a considerable amount of slack. If there is excess movement in slide assembly, this can be adjusted.

3. If the slide has excess movement, go to details below for adjustment procedure.

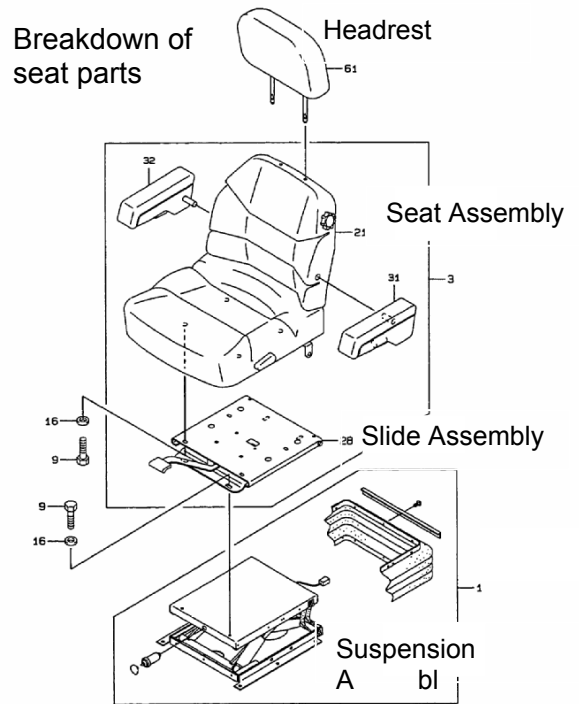

There are repair kits available through the KCM Parts Dept. for slide assemblies & other parts.

There are two types of seat slides up to current production. On the following pages, seat slide adjustment procedures are laid out according to serial number of seat.



# PRODUCT SUPPORT.....SERVICE NEWS

<b>BULLETIN NO.:</b> 2004-001	<b>DATE:</b> Oct. 8, 2004	<b>PAGE:</b> 2 of 3
<b>TITLE:</b> Seat Slide Adjustment		<b>RELEASE:</b> Dealer/Customer
<b>SECTION:</b> Cab [All with Sears Mfg. Seat]		<b>MODEL:</b> 50~115ZIV-2/ZV

## Detail (cont'd):

This illustrates adjusting the seat slide on earlier vintage of seat production. Applies to Sears Mfg. Seat slide p/n SA14017.901\* [all made prior to s/n SUS3199332 (before April 1, 2002)]. Adjust on both right and left side as needed. Remove upper seat cushion assembly from slide prior to doing these steps. Lubricate slide with light oil as needed, and move slide through F/R length of travel after lubricating. Detailed instructions below.

- 1.) Loosen locknuts. (5/16" nut, requires a 1/2" socket to do this.) This will permit free motion of bracket on base plate due to slot shown below.
- 2.) Using a screwdriver or bar of enough size to force bracket outward, apply tension to the "puck" brackets. With tension still applied do the following.
- 3.) Tighten locknuts. Check slack. Readjust if still loose. [More notes below.]

\* Supersedes to SA20660.901

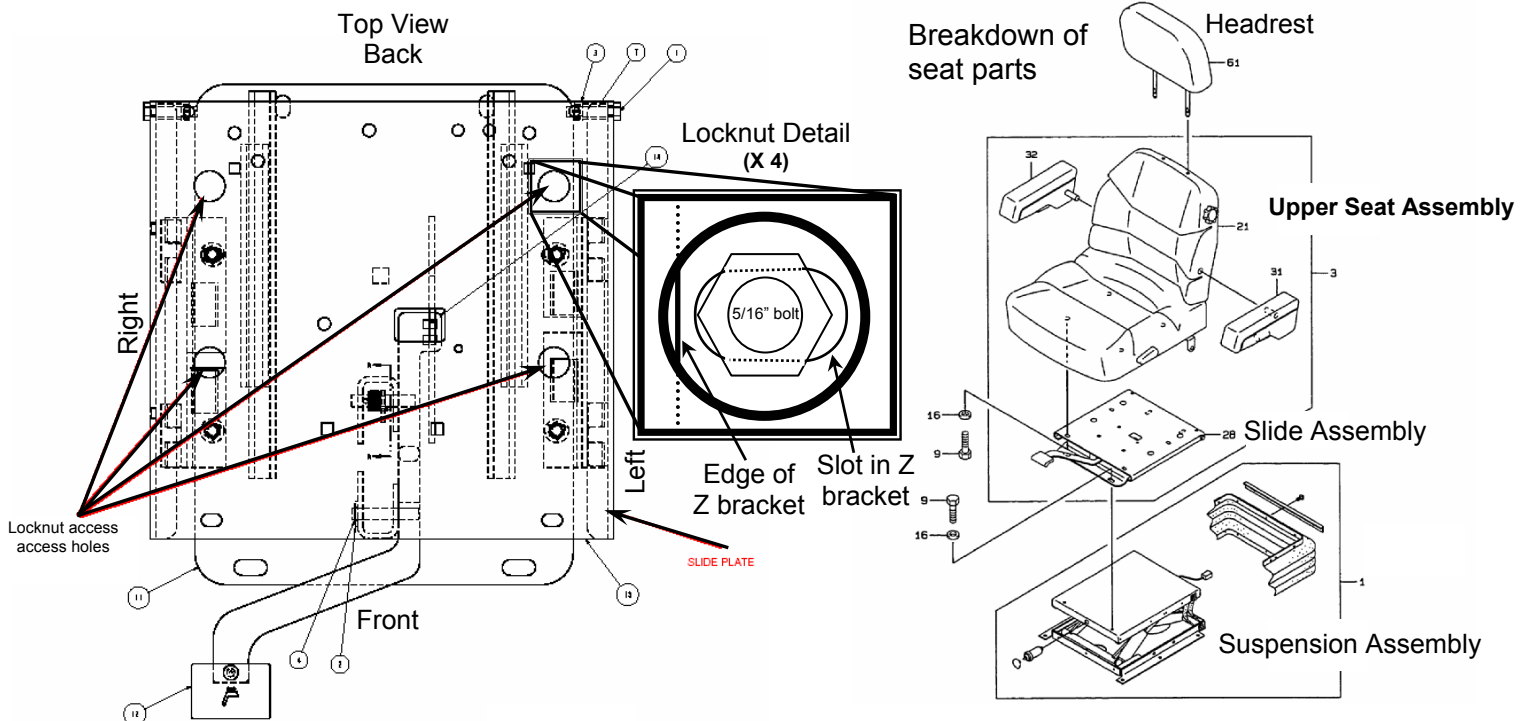

### Note:

Loosen and pry brackets outward so as to take up slack in slide mechanism, then tighten bracket again. Do this on either or both sides, as needed to remove slack. Try to maintain the slide as "centered" as possible.

The "puck" block rests over top of bracket, and the inside of the bracket and "puck" block will move out as shown and will tighten slide.

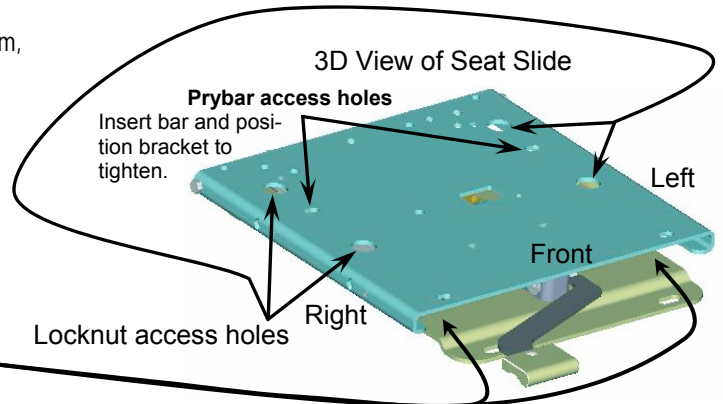
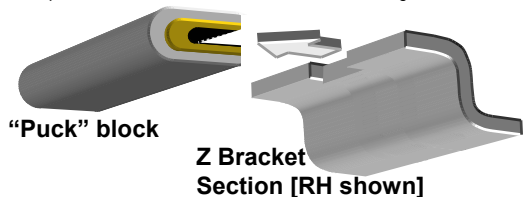



# PRODUCT SUPPORT.....SERVICE NEWS

**BULLETIN NO.: 2004-001**

**DATE: Oct. 8, 2004**

**PAGE: 3 of 3**

**TITLE: Seat Slide Adjustment**

**RELEASE: Dealer/Customer**

**SECTION: Cab [All with Sears Mfg. Seat]**

**MODEL: 50~115ZIV-2/ZV**

### Detail (cont'd):

This illustrates adjusting seat slide on later vintage of seat production. Applies to Sears Mfg. Seat Slide p/n \*SA20660.901 [s/n SUS3199332]. Adjustment screws are on right side only. Lubricate with light oil as needed, and move slide through the length of travel after lubricating.

- 1.) Position slide with adjusters at access holes as shown below to left [2D] and to right [3D]. \*In production after April 1, 2002 to date.
- 2.) Use 1/8" allen wrench and turn set screw clockwise until there is snug contact. Replaces SA14017.901.
- 3.) Turn set screw backwards enough so the slide will move freely, and the slack is minimal. Check side and lateral slack. Readjust if required.

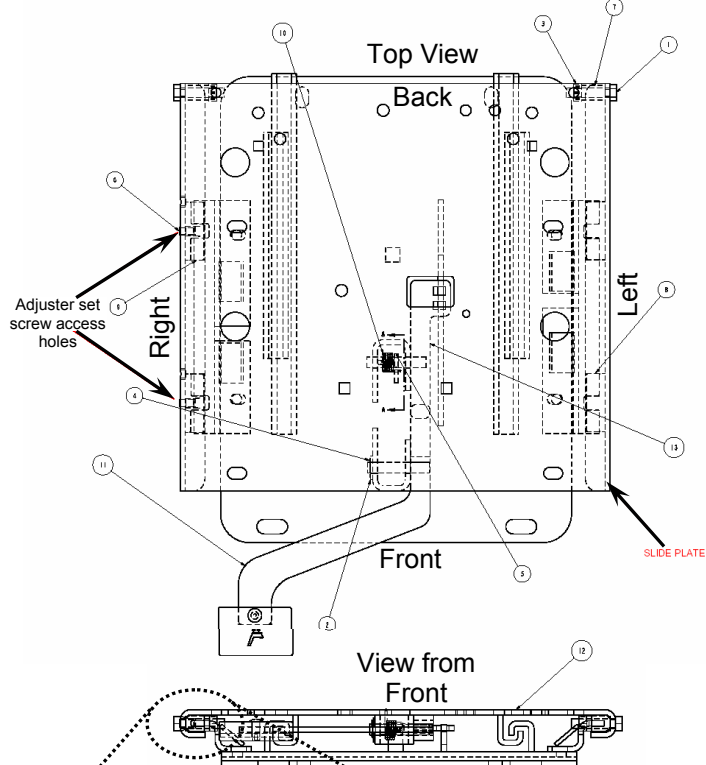

Right Side View

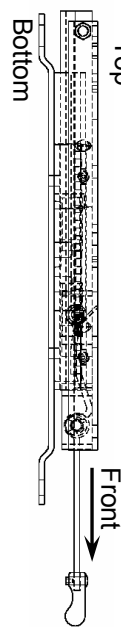

**Important: Do not overtighten, as slide may bind.**

3D View of Seat Slide

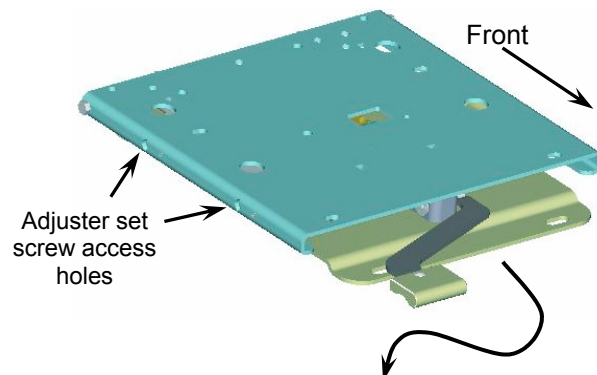

3D View of Slide Base



3D View of Slide Adjustment Bracket and Adjuster "Pucks"

