



PRODUCT SUPPORT.....SERVICE NEWS

BULLETIN NO.: 2007-005A	DATE: February 1, 2007 (Rev.)	PAGE: 1 of 5
TITLE: High efficiency fuel filter and pre-heater	RELEASE: Dealer/Customer	
SECTION: Power	MODEL: 115ZV-2	

Remove 2007-005 and discard and then replace with this Service News 2007-005A.

GENERAL:

The purpose of this document is provide clarification for a new all-in-one fuel filter, fuel / water separator and fuel heater that is installed on model 115ZV-2.

DETAIL:

Please see the attached pages.

The following two pages show the procedure from the Operation and Maintenance Manual for replacement of the fuel filter.

The last two pages illustrate parts in this all-in-one fuel filter, fuel/ water separator and fuel heater that is installed on model 115ZV-2. This is general information only & has been provided only to help illustrate the composition of the filter. Parts are available for replacement through the normal Kawasaki parts department channels. (Part numbers on following pgs.)

IMPORTANT

Always use only clean fuel. Never take a chance by using fuel from an unclean source. Serious injection system damage will result from use of unclean fuel.

Replace Fuel Filter Cartridge

CAUTION

Escaping fuel is flammable and harmful to skin.

Do not smoke while draining moisture and sediment from fuel filter.

Do not drain with engine running.

Do not allow fuel to remain on skin for extended period of time. Wash thoroughly with soap and water.

1. Park the machine on level ground, apply the parking brake, lower the attachment to the ground, and stop the engine.
2. Place a suitable drain pan (about 4 liter (1 gal)) under the fuel filters.

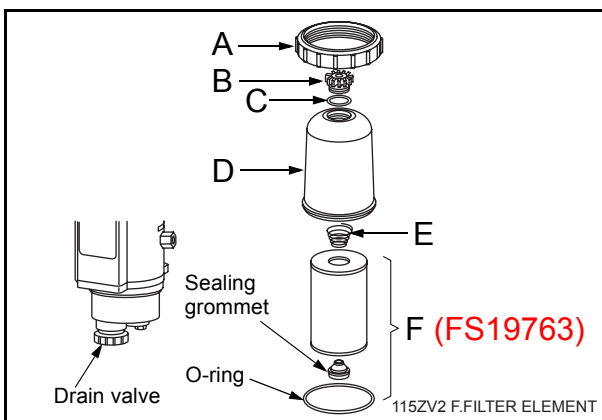
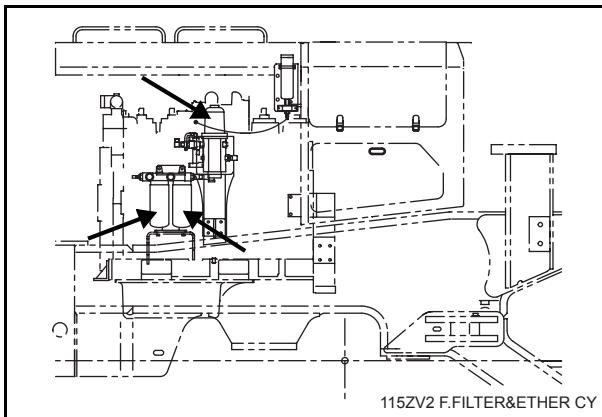

- A: Collar (use tool #3944451 S)
B: Vent Cap (Vent Cap and Assembly, use tool #3944451 S)
C: Vent Seal (Vent Cap and Assembly)
D: Cover
E: Filter Spring
F: Filter Element (7 micron, part # FS19763, Includes seals & o-rings)

3. Loosen the vent cap (B) to break the air lock in the filter.
4. Open the drain valve and drain the fuel level below the collar, then close the drain valve.
5. Using the Collar/Vent Cap Wrench (Fleetguard part number 3944451 S), remove the clear cover (D) from the fuel processor by removing the collar (A).

Remove the o-ring from the base of the cover. (A new o-ring is supplied with the new filter.) Remove the filter element (F) by pulling upward and twisting slightly.

Be sure the sealing grommet is removed from the center stud.

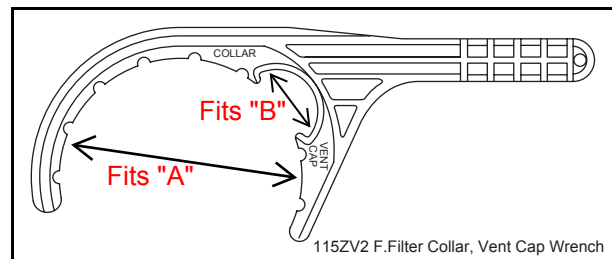

6. Install the new filter element (supplied with a sealing grommet already inserted into the element) on the processor center stud by pushing down and twisting slightly.

After checking to make sure the new o-ring (supplied with the filter) at the base of the cover is in place, install the cover (D) and collar (A).

Hand tighten the collar (A) until seated. Do not use tools to tighten.

7. Remove the vent cap (B) from the top of the clear cover by turning the vent cap counter-clockwise.

Fill the clear cover with enough clean fuel to cover the bottom half of the filter element.

Make sure the new o-ring (supplied with the filter) is installed on the vent cap.

Reinstall the vent cap and tighten by hand only.

Every 250 Hours or 1 Month

8. Start the engine. When the lubrication system reaches its normal operating pressure, increase engine speed for one minute.

After the air is purged, loosen the vent cap (B) until the fuel level lowers to just above the collar. Tighten the vent cap by hand only.

NOTE

The clear filter cover will not fill completely during engine operation. It will gradually fill over time and the fuel level will rise as the filter becomes clogged.

9. Hand tighten the collar again while the engine is running. To avoid damage, do not use tools to tighten the collar.

Cartridge type fuel filter (2pcs)

10. Remove and properly dispose of the fuel filters.
11. Clean the filter head gasket surface.
12. Apply a light film of clean engine oil to the gasket surface of the new filters.
13. Fill the filters with **clean fuel (must be very clean)**.
14. Install the filter on the filter head.

Turn it until the gasket contacts the filter head surface.

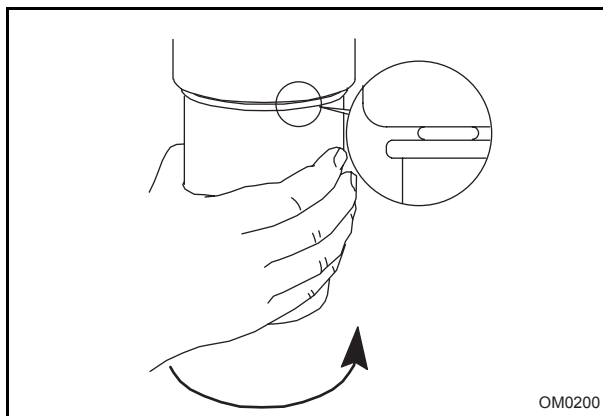

15. Tighten the filter an additional one-half to three-fourths turn after the gasket contacts the filter head surface. Follow the instructions supplied with the filter.

IMPORTANT

Do not over tighten the filter.

16. Turn the starter switch key to the ON position and leave it about 2 minutes.
17. Then, turn the starter switch key back to the OFF position and leave it about 15 seconds.
18. Repeat steps 16 and 17 twice.
The lift pump will automatically run to prime while the starter switch key is at ON position. Visually confirm that the fuel comes up into the clear cover (D).
19. Turn the starter switch key to the START position to run the engine.
Do not leave the key at the START position for 20 seconds or longer.
20. If you failed to start the engine, repeat steps 16 through 19.
21. After replacing the filter and/or oil, reset the interval timer for the replacement. Go to the timer reset screen of the MODM, and reset the corresponding replacement interval.



FH234 Series Industrial Pro™ Diesel Fuel Filtration System

Filter Element

Quick change, easy disposal

Self Priming Port

Just spin off the cap, pour in fuel and restart the engine with clean, filtered fuel

Eliminate Unnecessary Changes & Maintenance

- Large capacity filter for extended life
- Extended filter change intervals
- Common filters with Fuel Pro FH230 Series
- Optional inlet / outlet fuel hose connection and routing locations
- Low restriction check valve eliminates loss of fuel prime when draining or changing the filter
- High fuel flow rates attainable by joining Industrial Pro units with adapter kits
- Water-In-Fuel (WIF) sensor is available

FS 19763



Clear Cover

See when NOT to change filters
See fuel condition and flow

Seeing is Believing®

Five Minute Filter Change

- Dry Filter Changes: Drain fuel below collar and replace
- No Fuel Spills: Removing standard filters full of fuel can be messy and hazardous
- Back-Up Emergency Provision: The Industrial Pro also accepts standard spin-on filters in an emergency
- Sturdy, quick-acting drain for water and contaminants

Forged Aluminum Construction

Anodized coating for extreme duty applications

Clear Water Bowl

Drain Valve

Clean operation

Fuel Warmer Options

- Available with 12 or 24 V preheater

Featuring StrataPore™

- Maximum strength and durability
- Improved efficiency and longer life
- The best Fuel / Water Separation available
- Reduced restriction to flow
- Supports extended service intervals
- Maintains its Fuel / Water Separation efficiency over time

Dual Units



Triplex Units



Suggested Markets

- Oil & Gas
- Power Generation
- Construction / Mining
- Off-Road
- Stationary

All-In-One Fuel Filter, Fuel / Water Separator and Fuel Heater

Fleetguard Family of Brands



Housings Available

Housing Part No.	Fuel Flow (gph)	Filter Type	Micron Rating	Filter Part Number	Bottom Plate	Heat	Drain	WIF	Fuel In & Fuel Out	Fuel In & Out Port
Single										
FH23400	200	Cartridge	7	FS19763	FG Bowl	N/A	Yes	*	Left or Right	3/4" NPT
FH23402	200	Cartridge	7	FS19763	FG Bowl	12 V, 120 W DC	Yes	*	Left or Right	3/4" NPT
FH23401	200	Cartridge	7	FS19763	FG Bowl	24 V, 150 W DC	Yes	*	Left or Right	3/4" NPT
Double (No Shutoff Valve) and Duplex (Includes Shutoff Valve)										
FH23435	400	Cartridge	25	FS19765	FG Bowl	N/A	Yes	*	Tee	1" NPT
FH23439	400	Cartridge	7	FS19763	FG Bowl	N/A	Yes	*	Tee	1" NPT
FH23440	400	Cartridge	7	FS19763	FG Bowl	N/A	Yes	*	4-Way Valve	1" NPT
Triple (No Shutoff Valves) and Triplex (Includes Shutoff Valves)										
FH23441	600	Cartridge	7	FS19763	FG Bowl	N/A	Yes	*	Tee	1" NPT
FH23438	600	Cartridge	7	FS19763	FG Bowl	N/A	Yes	*	4-Way Valve	1" NPT

* Water-In-Fuel sensor (WIF), part number 3911940 S, available separately

Dimensions

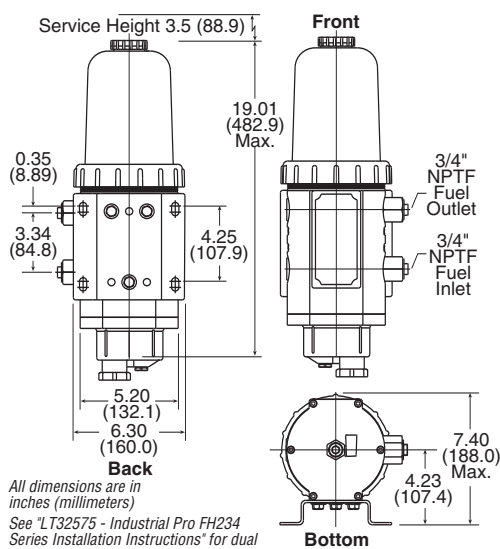

All dimensions are in inches (millimeters)
See "LT32575 - Industrial Pro FH234 Series Installation Instructions" for dual and triple unit installation dimensions

Adapter Kits

Using Industrial Pro Adapter Kit (part number 3945216 S) you can join two Industrial Pro units to double the fuel flow rate to 400 gph (1515 lph) or join three units to triple the fuel flow rate to 600 gph (2272 lph). Each kit contains two adapters.

To link two Industrial Pro units, choose an Industrial Pro Adapter Kit with Service (part number 3945960 S). Filter changes are performed with the engine running.

Typical Installation

(install between the fuel tank and the transfer fuel pump)

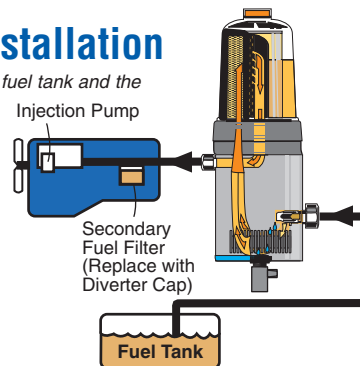

Specifications

Specification	Single Unit	Dual / Duplex Unit	Triple / Triplex Unit
Height Overall	19.01" (482.85 mm)	19.01" (482.85 mm)	19.01" (482.85 mm)
Depth Overall	7.40" (188 mm)	7.40" (188 mm)	7.40" (736.6 mm)
Width, Max. (w/ bracket)	6.30" (160.0 mm)	18.75" (476.3 mm)	29.00" (160.02 mm)
Mount Bracket Centers			
Vertical	4.25" (108 mm)	6.20" (157.5 mm)	6.20" (157.5 mm)
Horizontal	5.20" (132 mm)	6.75" (171.5 mm)	6.75" (171.5 mm)
Weight (Dry)	17.7 lbs (6.6 kg)	41.4 lbs (15.5 kg)	64.1 lbs (23.9 kg)
Fuel Capacity (w/o filter)	.37 gal (1400 ml)	.74 gal (2801 ml)	1.11 gal (4202 ml)
Fuel Connections	3/4" NPTF	1" NPTF	1" NPTF
Fuel Flow Rate	200 gph (757 lph)	400 gph (1515 lph)	600 gph (2272 lph)
Recommended Appl.	Heavy Duty Engines	Heavy Duty Engines	Heavy Duty Engines
Water Trap Capacity	20.3 fl oz (600 ml)	40.6 fl oz (1200 ml)	60.9 fl oz (1800 ml)
Filter Replacement	FS19763*	FS19763*	FS19763*
Filter Service Clearance	Min. 3.5" (88.9 mm)	Min. 3.5" (88.9 mm)	Min. 3.5" (88.9 mm)
Electrical Heater	12 VDC, 150 W, 13 A ± 3 A	N/A	N/A
	24 VDC, 150 W, 6.5 A ± 2 A		

* Standard Replacement Filter Elements. Other filter options at different Micron Ratings are available. Specifications subject to change without notice.



NELSON



UNIVERSAL

